

DXN MARKETING PLAN

Definition of Terms

PV	: Point Value, for qualification and status.
SV	: Sales Value, for calculation of Bonus and Incentive.
Personal Point Value (PPV) / Personal Sales Value (PSV)	: Total PV/SV generated from all personal cash bills transacted in a month.
Personal Group Point Value (PGPV) / Personal Group Sales Value (PGSV)	: Total PV/SV generated in a month by all downline distributors within personal group (ie. excluding breakaway QSAs) and own PPV/PSV.
Diamond Group Point Value (DGPV) / Diamond Group Sales Value (DGSV)	: Total PV/SV generated in a month by all downline distributors within your diamond group (ie. excluding breakaway QSDs) and own PPV/PSV.
Qualified Star Agent (QSA)	: Any SA who maintains 30 PPV and 100 PGPV in a month.
Qualified Star Diamond (QSD)	: Any Diamond who qualifies for 37% Star Group Bonus.
Travel Seminar Qualifier	: Any SA and above who meets the Yearly Travel Seminar Incentive Points (TSIP) Quota set for the year.

Introduction of Remuneration

1) Retail Profit -----	15% - 25%
2) Bonus (71%) and Cash Incentive (MXN25,200)	
a) Group Bonus -----	6% - 21%
b) Star Group Bonus -----	25% - 37%
c) Development Bonus -----	15%
d) International Profit Sharing -----	2%
e) Leadership Bonus -----	15%
f) Travel Seminar Incentive -----	2%
g) One Time HP Cash Incentive -----	MXN3,600
h) One Time Oversea Trip Cash Incentive -----	MXN21,600

Status

Status	Condition
Distributor	Membership Fee (MXN450) Age 18 years + and a sponsor.
Star Agent (SA)	Achieves accumulated Group Sales of 1,800PV
Star Ruby (SR)	Sponsors 3 First Generation Star Agents (SA)
Star Diamond (SD)	With 6 First Generation Star Agents (SA) & qualifies for 37% Star Group Bonus.
Senior Star Diamond (SSD)	Star Diamond who sponsors 2 Star Diamonds *
Double Diamond (DD)	Star Diamond who sponsors 4 Star Diamonds *
Triple Diamond (TD)	Star Diamond who sponsors 6 Star Diamonds *
Gold Diamond (GD)	Star Diamond who sponsors 8 Star Diamonds *
Crown Diamond (CD)	Star Diamond who sponsors 10 Star Diamonds *
Senior Crown Diamond (SCD)	Star Diamond who sponsors 12 Star Diamonds *
Double Crown Diamond (DCD)	Star Diamond who sponsors 14 Star Diamonds *
Triple Crown Diamond (TCD)	Star Diamond who sponsors 16 Star Diamonds *
Gold Crown Diamond (GCD)	Star Diamond who sponsors 18 Star Diamonds *
Crown Ambassador (CA)	Star Diamond who sponsors 20 Star Diamonds *

* As per dynamic compression.

Remuneration in DXN Marketing Plan

1. Retail Profit (15% - 25%)

Direct profit for distributors is when they sell DXN products to non-DXN members. Retail profit is the difference between distributor price and retail price.

2. Group Bonus (6% - 21%)

To be entitled to this Group Bonus, you need to maintain 30 PPV each month.

Accumulated Group PV	Bonus
1,800 and above	21% *
1,300	18%
800	15%
400	12%
120	9%
30	6%

* If a Star Agent (21%) maintains 30 PPV and 100 PGPV **, he will become a Qualified Star Agent (25%).

3. Star Group Bonus (25% - 37%)

*To be entitled to this Star Group Bonus, you must be a SA and maintain 30 PPV and 100 PGPV ** (QSA).*

No. of SA (1st Generation)	No. of Qualified SA Lines	DGPV	Bonus
6	-	2,000	37%
	4	1,000 #	
5	-	1,200	35%
	4	800	
4	4	-	33%
3	3	-	31%
2	2	-	29%
1	1	-	27%
0	0	-	25%

** PGPV is inclusive of personal PV (i.e. 30 PPV + 70 non-QSA group PV).

For SSD and above, if the number of QSD is more than one, then the DGPV can be borrowed from one of the QSD and the number of QSD will be reduced by one.

4. Development Bonus (15%)

To be entitled to this Development Bonus, you must be a SA and maintain 30 PPV and 100 PGPV ** (QSA).

Level of Qualified SA	Bonus
1st Level	5%
2nd Level	4%
3rd Level	3%
4th Level	2%
5th Level	1%

** PGPV is inclusive of personal PV (i.e. 30 PPV + 70 non-QSA group PV).

5. International Profit Sharing (2%)

To be entitled to this International Profit Sharing (IPS) you must be a Qualified Star Diamond (QSD).

IPS Fund = Overall Company's Sales in SV X 2%
--

Your IPS entitlement

=	IPS Fund	X	$\frac{\text{Your IPS Point for the month}}{\text{Total IPS Point for all Qualified Star Diamond and above}}$
---	----------	---	---

• Your IPS Point calculation:

Level of Qualified SD	IPS Point			
Personal			DGSV	X 100%
1st Level QSD (L1)	+	L1	DGSV	X 50%
2nd Level QSD (L2)	+	L2	DGSV	X 40%
3rd Level QSD (L3)	+	L3	DGSV	X 30%
4th Level QSD (L4)	+	L4	DGSV	X 20%
5th Level QSD (L5)	+	L5	DGSV	X 10%

6. Leadership Bonus (15%)

To be entitled to this Leadership Bonus, you must be a *Qualified Star Diamond (QSD)*.

No. of Qualified SD Lines	1	2	3	4	5	6	7	8	9	10
1st Level QSD's DGSV	5%	5%	5%	5%	5%	5%	5%	5%	5%	5%
2nd Level and below QSD's DGSV (till 1st level of next qualifier)	-	3%	4.8%	5.8%	6.5%	7.1%	7.6%	8%	8.3%	8.5%
Minimum DGSV needed to Guarantee upline ('000)	12	24	36	48	48	48	48	48	48	48

No. of Qualified SD Lines	11	12	13	14	15	16	17	18	19	20
1st Level QSD's DGSV	5%	5%	5%	5%	5%	5%	5%	5%	5%	5%
2nd Level and below QSD's DGSV (till 1st level of next qualifier)	8.7%	8.9%	9.1%	9.3%	9.5%	9.6%	9.7%	9.8%	9.9%	10%
Minimum DGSV needed to Guarantee upline ('000)	48	48	48	48	48	48	48	48	48	48

7. Travel Seminar Incentive (2%)

This Travel Seminar Incentive(TSI) shall be used by the qualifier for the travel seminar organised by the Company only. It is not exchangeable for cash and also not transferable. A qualifier may claim up to maximum Travel Seminar Fare against his/her TSI for two(2) if married.

$$\text{Travel Seminar Incentive Fund} = \text{Company's Annual Sales in SV} \times 2\%$$

• To be shared as below:

- i) 50% of the Travel Seminar Incentive Fund (TSIF) to be shared amongst all SA and above who met the YEARLY TSIP QUOTA set for the year.
- ii) 50% of the Travel Seminar Incentive Fund (TSIF) to be shared amongst all SD and above who met the YEARLY TSIP QUOTA set for the year.

a) Travel Seminar Incentive for SA Qualifier (TSI_{SA})

$$\text{TSI}_{\text{SA}} = 50\% \times \text{TSIF} \times \frac{\text{Accumulated TSIP* for a SA Qualifier}}{\text{Total Accumulated TSIP for all SA Qualifiers}}$$

* Travel Seminar Incentive Point (TSIP) will be calculated monthly based on the following formula and to be accumulated for a year:

Level of Qualified SA	Monthly Travel Seminar Incentive Point (TSIP)			
Personal			PGSV	X 100%
1st Level QSA (L1)	+	L1	PGSV	X 50%
2nd Level QSA (L2)	+	L2	PGSV	X 40%
3rd Level QSA (L3)	+	L3	PGSV	X 30%
4th Level QSA (L4)	+	L4	PGSV	X 20%
5th Level QSA (L5)	+	L5	PGSV	X 10%

b) Travel Seminar Incentive for SD Qualifier (TSI_{SD})

$$\text{TSI}_{\text{SD}} = 50\% \times \text{TSIF} \times \frac{\text{Accumulated TSIP* for a SD Qualifier}}{\text{Total Accumulated TSIP for all SD Qualifiers}}$$

* Travel Seminar Incentive Point (TSIP) will be calculated monthly based on the following formula and to be accumulated for a year:

Level of Qualified SD	Monthly Travel Seminar Incentive Point (TSIP)			
Personal			DGSV	X 100%
1st Level QSD (L1)	+	L1	DGSV	X 50%
2nd Level QSD (L2)	+	L2	DGSV	X 40%
3rd Level QSD (L3)	+	L3	DGSV	X 30%
4th Level QSD (L4)	+	L4	DGSV	X 20%
5th Level QSD (L5)	+	L5	DGSV	X 10%

8. Hand Phone Cash Incentive (MXN3,600) - One Time Only

When you have 3 immediate SA who achieved 2,400 Accumulated GPV, then you will be entitled to receive this **One Time** Hand Phone Cash Incentive amounting to MXN3,600.

* Only personally sponsored downlines counted.

9. Oversea Trip Cash Incentive (MXN21,600) - One Time Only

When you have 5 immediate downlines who have received their Hand Phone Cash Incentive, then you will be entitled to receive this **One Time** Oversea Trip Cash Incentive amounting to MXN21,600.

* Only personally sponsored downlines counted.

Explanation On The DXN Marketing Plan Reward

1. Retail Profit (15% - 25%)

Direct profit for distributors is when they sell DXN products to non-DXN members. Retail profit is the difference between distributor price and retail price.

Example:

If you sell one bottle of RG-30 to a non-DXN member, you will earn the retail profit as below:

One bottle of RG-30	
Distributor Price	MXN127.00
Retail Price	MXN152.00

Therefore,

Retail Price – Distributor Price = Retail Profit

MXN152.00 – MXN127.00 = MXN25.00

YOUR retail profit is MXN25.00 (19.7% from distributor's price)

Minimum monthly Personal PV required for bonus entitlement (30PV).

* Example 1

Products	PV	SV
RG 90	15.8	190
GL 90	15.8	190
TOTAL	<u>31.6</u>	<u>380</u>

* Example 2

Products	PV	SV
Spirulina (500's)	18.7	192
Lingzhi Coffee 3 in 1	4.6	44
Morinzyme	5.5	66
Ganozhi Toothpaste	3.0	36
TOTAL	<u>31.8</u>	<u>338</u>

"The statements made on this page are hypothetical and merely meant to describe and explain the mechanisms of the Compensation plan and its various bonus features. Any statements made on this page are not meant as earnings claims, nor do they represent any promises or guarantees of specific earnings or earning potential. Specific earnings will be influenced by many factors."

* Assume 1PV = 12SV for all the following Bonuses and Incentives calculations.

2. Group Bonus (6%-21%)

CASE 1

If in the first month you have acquired 40PV and sponsored 3 new distributors with 200PV each:

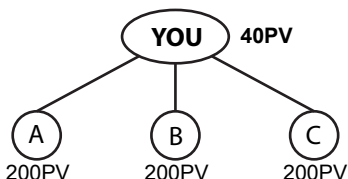

Personal PV (PPV) = 40PV
 Personal SV (PSV) = 480SV
 Personal Group PV (PGPV) = 640PV
 Personal Group SV (PGSV) = 7,680SV

Your Group Bonus = $(7,680SV \times 12\%) - (2,400SV \times 9\%)$
 $- (2,400SV \times 9\%) - (2,400SV \times 9\%)$
 = MXN921.60 - MXN216.00 - MXN216.00 - MXN216.00
 = MXN273.60

Therefore:

Your Group Bonus is MXN273.60 and Group Bonus for A,B and C is MXN216.00 each.

CASE 2

If YOU have acquired 24PV and each one of your downline achieved 200PV;

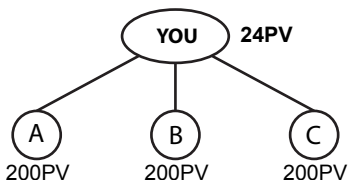

Personal PV (PPV) = 24PV
 Personal Group PV (PGPV) = 624PV

You are not qualified to receive any bonus because your Personal PV is less than 30PPV. To qualify for Group Bonus, YOU must have a minimum of 30PPV.

"The statements made on this page are hypothetical and merely meant to describe and explain the mechanisms of the Compensation plan and its various bonus features. Any statements made on this page are not meant as earnings claims, nor do they represent any promises or guarantees of specific earnings or earning potential. Specific earnings will be influenced by many factors."

3. Star Group Bonus (25% - 37%)

CASE 1

If YOU are a Star Ruby (SR) and have sponsored 3 Star Agents (SA) and 2 distributors;

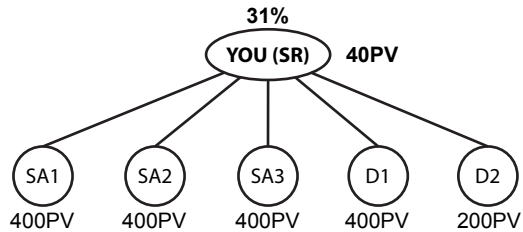

Personal PV (PPV) = 40PV
 Personal SV (PSV) = 480SV
 Personal Group PV (PGPV) = 640PV
 Personal Group SV (PGSV) = 7,680SV

Your Star Group Bonus = (22,080SV X 31%) - (4,800SV X 25%)
 - (4,800SV X 25%) - (4,800SV X 25%)
 - (4,800SV X 12%) - (2,400SV X 9%)
 = MXN6,844.80 - MXN1,200.00 - MXN1,200.00
 - MXN1,200.00 - MXN576.00 - MXN216.00
 = MXN2,452.80

Therefore:

YOUR Star Group Bonus is MXN2,452.80.
SA1, SA2 and SA3 will earn MXN1,200.00 each.
Group Bonus for D1 is MXN576.00 and D2 is MXN216.00.

"The statements made on this page are hypothetical and merely meant to describe and explain the mechanisms of the Compensation plan and its various bonus features. Any statements made on this page are not meant as earnings claims, nor do they represent any promises or guarantees of specific earnings or earning potential. Specific earnings will be influenced by many factors."

CASE 2

If YOU are a Star Diamond with **6 SA** (1st Generation), 30PPV and 160 PGPV.
 At the same time, YOU have some downlines with the status of Star Ruby (SR) and Star Agent (SA) who have at least 30PPV.

The Star Group Bonus entitlement (%) for YOU and your downlines will be as follow:

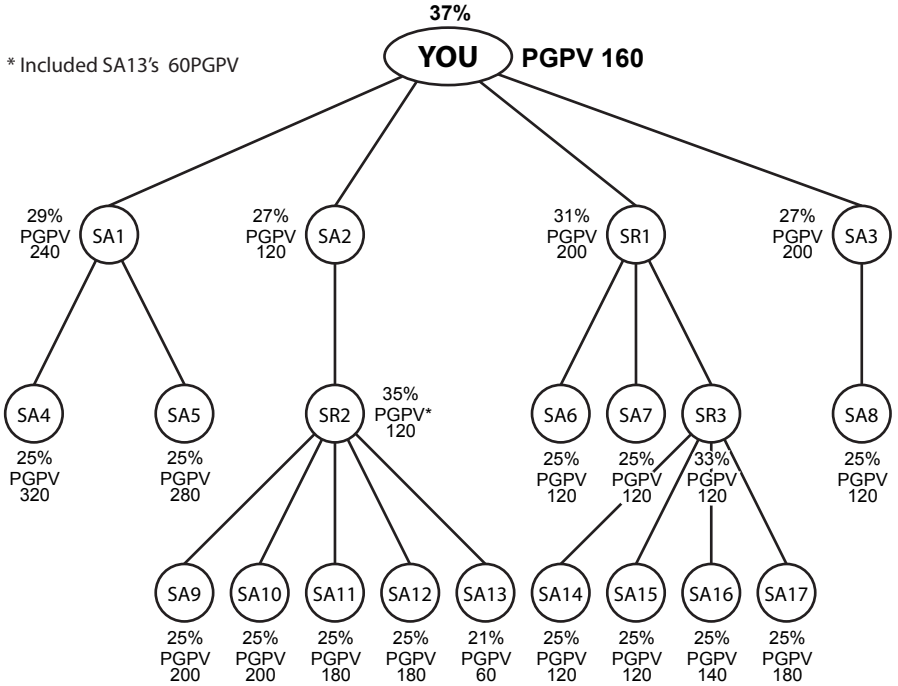

Star Group Bonus (%)

	Status	No of Qualified SA Lines	PPV	PGPV	DGPV	SGB entitlement (%)
YOU	SD	4	30	160	3,440	37%
SA1	SA	2	30	240		29%
SA2	SA	1	30	120		27%
SR1	SR	3	30	200	1,120	31%
SR2	SR	4	30	120	880	35%
SR3	SR	4	30	120	680	33%
SA4	SA	0	30	320		25%
SA13	SA	0	30	60		21%

"The statements made on this page are hypothetical and merely meant to describe and explain the mechanisms of the Compensation plan and its various bonus features. Any statements made on this page are not meant as earnings claims, nor do they represent any promises or guarantees of specific earnings or earning potential. Specific earnings will be influenced by many factors."

CASE 3

If YOU are a Star Ruby with **5 SA** (1st Generation), 30PPV and 200PGPV.
 At the same time, YOU have downlines with the status of Star Ruby (SR) and Star Agent (SA).
 Some of the SR or SA are inactive (i.e. SA1, SA2, SA5 & SR).

* Included SA4's 80PGPV

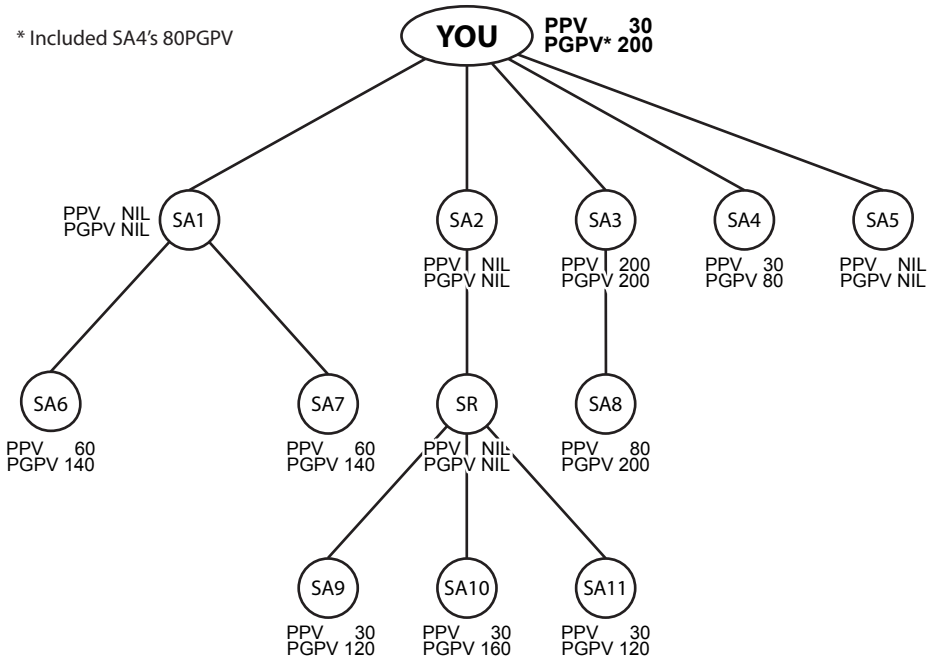

Therefore, YOU are entitled to 35% of Star Group Bonus even you have only 3 qualified SA lines. It is because YOU have 5 SA (1st Generation) and obtained 1,280 DGPV.

"The statements made on this page are hypothetical and merely meant to describe and explain the mechanisms of the Compensation plan and its various bonus features. Any statements made on this page are not meant as earnings claims, nor do they represent any promises or guarantees of specific earnings or earning potential. Specific earnings will be influenced by many factors."

4. Development Bonus (15%)

CASE 1

For Development Bonus, if YOU are a Star Ruby (SR) and have downlines as below:

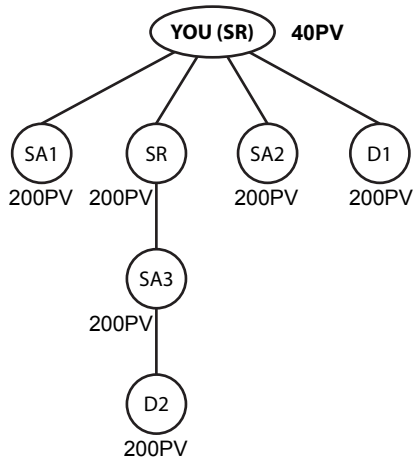

Personal PV (PPV) = 40PV
 Personal Group PV (PGPV) = 240PV

YOUR Development Bonus = (7,200SV x 5%) + (4,800SV x 4%)
 = MXN360 + MXN192
 = MXN552.00

Therefore:

YOUR Development Bonus is MXN552.00

"The statements made on this page are hypothetical and merely meant to describe and explain the mechanisms of the Compensation plan and its various bonus features. Any statements made on this page are not meant as earnings claims, nor do they represent any promises or guarantees of specific earnings or earning potential. Specific earnings will be influenced by many factors."

CASE 2

For Development Bonus, if YOU are a Star Ruby (SR) and have downlines as below:

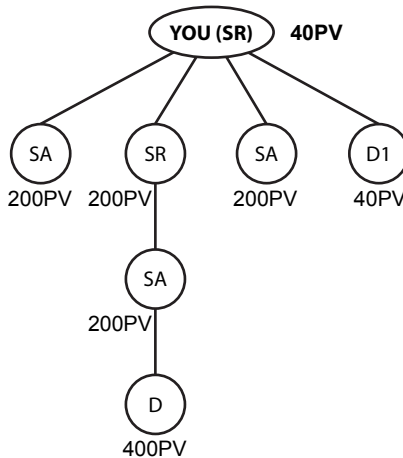

Personal PV (PPV) = 40PV

Personal Group PV (PGPV) = 80PV

YOU are not qualified to earn the development bonus because your Personal Group PV is less than 100PV.

"The statements made on this page are hypothetical and merely meant to describe and explain the mechanisms of the Compensation plan and its various bonus features. Any statements made on this page are not meant as earnings claims, nor do they represent any promises or guarantees of specific earnings or earning potential. Specific earnings will be influenced by many factors."

5. International Profit Sharing (2%)

EXAMPLE

YOU are a Senior Star Diamond (SSD) and have downlines of Star Diamond (SD) and above.

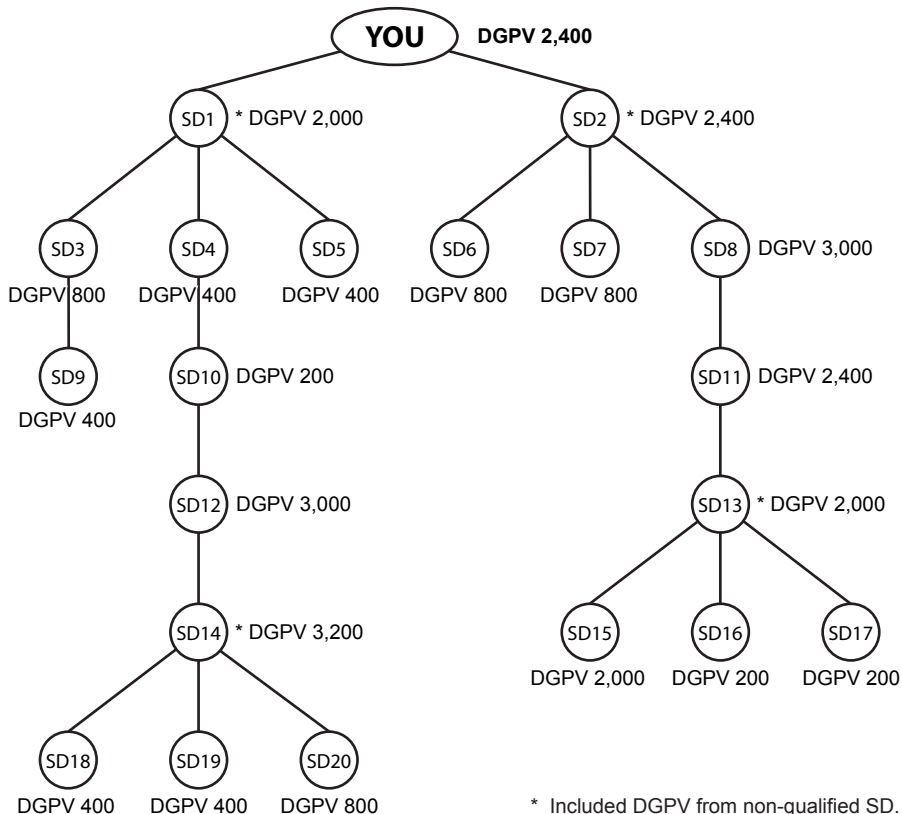

* Included DGPV from non-qualified SD.

Non-qualified SD: SD3, SD4, SD5, SD6, SD7, SD9, SD10, SD16, SD17, SD18, SD19 & SD20

Qualified SD : YOU, SD1, SD2, SD8, SD11, SD12, SD13, SD14 & SD15

Assumptions:-

- i) 1 PV equals to 12 SV.
- ii) There are 68 Star Diamonds and above in the company and the Total IPS Point is 2,400,000 points.
- iii) Total company's sales for that particular month is 10,000,000 SV.

"The statements made on this page are hypothetical and merely meant to describe and explain the mechanisms of the Compensation plan and its various bonus features. Any statements made on this page are not meant as earnings claims, nor do they represent any promises or guarantees of specific earnings or earning potential. Specific earnings will be influenced by many factors."

IPS Point for YOU:

	DGSV		IPS points
YOU	28,800	X 100%	= 28,800
1st Level: SD1 + SD2	52,800	X 50%	= 26,400
2nd Level: SD12 + SD8	72,000	X 40%	= 28,800
3rd Level: SD14 + SD11	67,200	X 30%	= 20,160
4th Level: SD13	24,000	X 20%	= 4,800
5th Level: SD15	24,000	X 10%	= 2,400
YOUR Total IPS Point			<u>111,360</u>

Therefore:

YOUR International Profit Sharing

$$= 2\% \times 10,000,000\text{SV} \times \frac{111,360\text{pts}}{2,400,000\text{pts}}$$

$$= \underline{\text{MXN9,280}}$$

"The statements made on this page are hypothetical and merely meant to describe and explain the mechanisms of the Compensation plan and its various bonus features. Any statements made on this page are not meant as earnings claims, nor do they represent any promises or guarantees of specific earnings or earning potential. Specific earnings will be influenced by many factors."

6. Leadership Bonus (15%)

CASE 1

YOU are a Senior Star Diamond (SSD) and have qualified for 37% Star Group Bonus.
 Every Circle (from A1 to C6) represents a SD and above.
 All SDs have qualified for 37% Star Group Bonus.

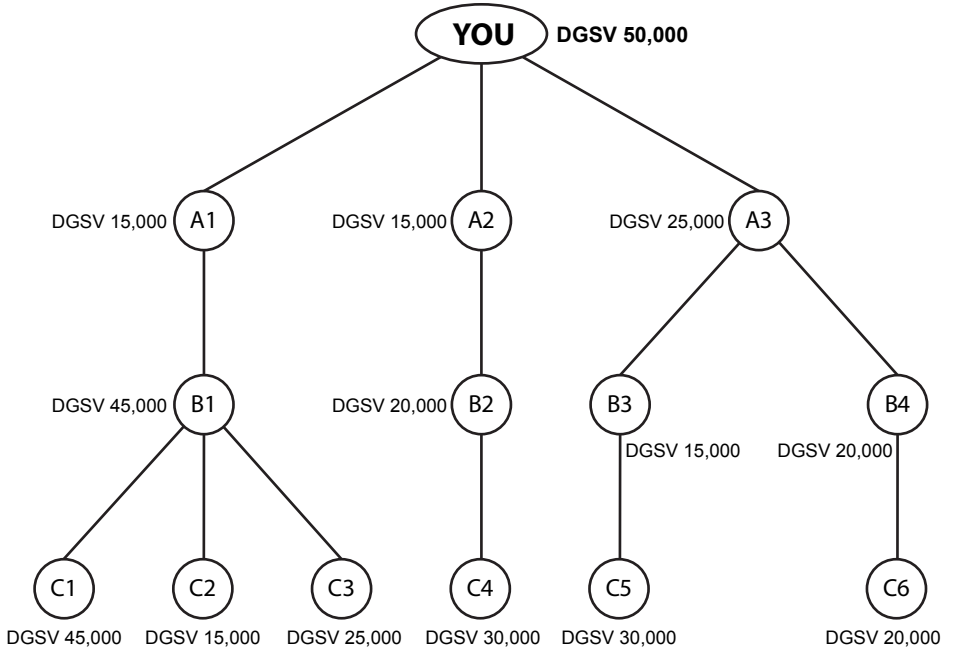

YOUR Leadership Bonus:

1st Level qualified SD:

$$A1 + A2 + A3 = 55,000\text{SV} \times 5.0\% = \text{MXN } 2,750$$

2nd Level and below qualified SD:

$$B1 + C1 + C2 + C3 + B2 + C4 + B3 + B4 = 215,000\text{SV} \times 4.8\% = \text{MXN } 10,320$$

$$C5 + C6 = 50,000\text{SV} \times 1.8\% = \text{MXN } 900$$

YOUR Leadership Bonus

MXN 13,970

"The statements made on this page are hypothetical and merely meant to describe and explain the mechanisms of the Compensation plan and its various bonus features. Any statements made on this page are not meant as earnings claims, nor do they represent any promises or guarantees of specific earnings or earning potential. Specific earnings will be influenced by many factors."

CASE 2

YOU are a Double Diamond (DD) and have qualified for 37% Star Group Bonus.
 Every Circle (from A1 to C6) represents a SD and above.
 All SDs have qualified for 37% Star Group Bonus with the exception of A1, A2, A5, & B5.

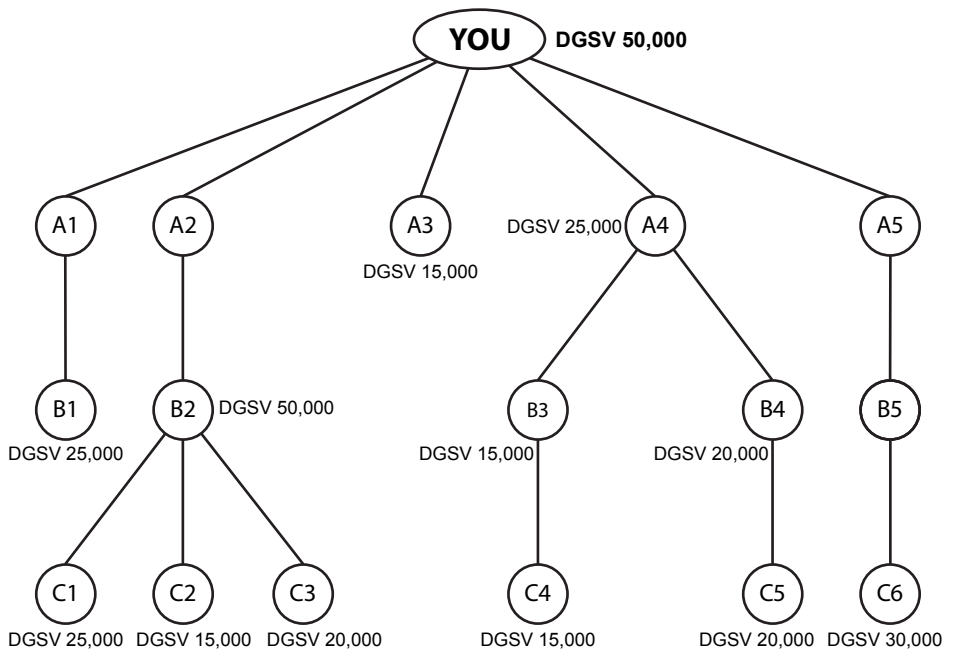

YOUR Leadership Bonus:

1st Level qualified SD:
 B1 + B2 + A3 + A4 + C6 = 145,000SV X 5.0% = MXN7,250

2nd Level and below qualified SD:
 C1 + C2 + C3 + B3 + B4 = 95,000SV X 6.5% = MXN6,175
 C4 + C5 = 35,000SV X 3.5% = MXN1,225

YOUR Leadership Bonus MXN14,650

"The statements made on this page are hypothetical and merely meant to describe and explain the mechanisms of the Compensation plan and its various bonus features. Any statements made on this page are not meant as earnings claims, nor do they represent any promises or guarantees of specific earnings or earning potential. Specific earnings will be influenced by many factors."

CASE 3

YOU are a Double Diamond (DD) and have qualified for 37% Star Group Bonus.
 Every Circle (from A1 to C6) represents a SD and above.
 All SDs have qualified for 37% Star Group Bonus with the exception of A1, A2, A5, & B5.

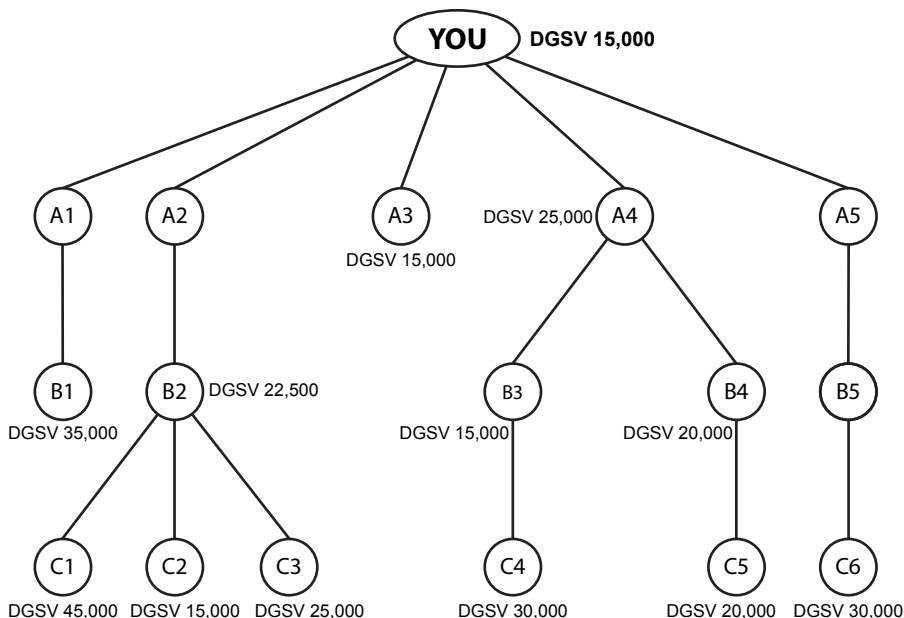

YOUR Leadership Bonus:

1st Level qualified SD:

B1 + B2 + A3 + A4 + C6

Add: Guarantee from Downline (B2)

Less: Guarantee Upline (YOU)

13,500SV
 127,500SV

(33,000SV)

2nd Level and below qualified SD:

C1 + C2 + C3 + B3 + B4

Less: Guarantee Upline (B2)

108,000SV X 5.0% = MXN 5,400.00

120,000SV

(13,500SV)

C4 + C5

YOUR Leadership Bonus

106,500SV X 6.5% = MXN 6,922.50

50,000SV X 3.5% = MXN 1,750.00

* YOU need to guarantee upline 48,000 DGSV.

* B2 need to guarantee upline 36,000 DGSV.

MXN14,072.50

"The statements made on this page are hypothetical and merely meant to describe and explain the mechanisms of the Compensation plan and its various bonus features. Any statements made on this page are not meant as earnings claims, nor do they represent any promises or guarantees of specific earnings or earning potential. Specific earnings will be influenced by many factors."

CASE 4

YOU are a Crown Ambassador (CA) and have 20 first generation Crown Ambassadors (CAs) with 50,000 DGSV each. All CAs have 20 Qualified SDs with 50,000 DGSV each.

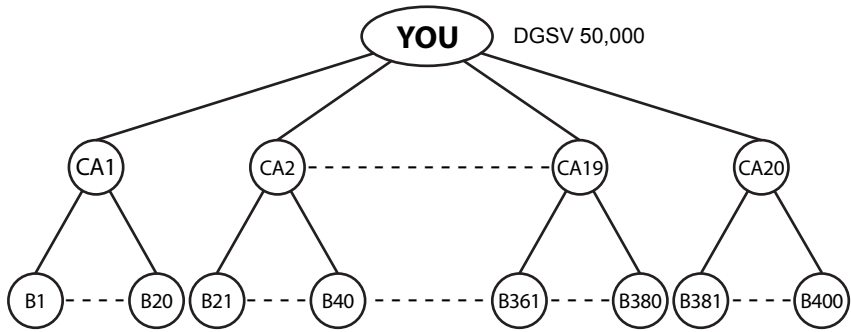

Therefore:

Your Leadership Bonus

1st Level Qualified SD: 50,000 DGSV X 20 X 5%	=	MXN 50,000
2nd Level Qualified SD: 50,000 DGSV X 400 X 10%	=	MXN2,000,000
		<u><u>MXN2,050,000</u></u>

"The statements made on this page are hypothetical and merely meant to describe and explain the mechanisms of the Compensation plan and its various bonus features. Any statements made on this page are not meant as earnings claims, nor do they represent any promises or guarantees of specific earnings or earning potential. Specific earnings will be influenced by many factors."

7. Travel Seminar Incentive (2%)

The company will allocate 2% of company's Annual Sales in SV as the Travel Incentive Fund. It will be shared amongst the SA Qualifiers & SD Qualifiers and used to subsidise the Travel Seminar.

Assumption:-

- Company Annual Sales is 90,000,000 SV.
- Travel Seminar Incentive Fund = $2\% \times 90,000,000 \text{ SV}$
= MXN1,800,000

A) Travel Seminar Incentive for SA Qualifiers.

Assumption:-

- i Total Accumulated TSIP for all SA Qualifiers is 4,000,000 points.
- ii YOUR Accumulated TSIP as a SA Qualifier is 60,000 points.
- iii Yearly TSIP QUOTA for SA is 50,000 points.
- iv Estimated cost of Travel Seminar for SA Qualifier is MXN7,500/pax.

Therefore:

Your Travel Seminar Incentive as SA Qualifier

$$= 50\% \times \text{MXN}1,800,000 \times \frac{60,000 \text{ pts}}{4,000,000 \text{ pts}} = \underline{\underline{\text{MXN}13,500}}$$

Note: Your TSI is more than enough to pay for one person to attend the Travel Seminar. So, you can either go for this Travel Seminar by yourself without any cash refund for the excess incentive or you may bring along your spouse by paying additional MXN1,500 as the short amount for the fare of two.

B) Travel Seminar Incentive for SD Qualifiers

Assumption:-

- i Total Accumulated TSIP for all SD Qualifiers is 5,000,000 points.
- ii Your Accumulated TSIP as a SD Qualifier is 140,000 points.
- iii Yearly TSIP QUOTA for SD is 125,000 points.
- iv Estimated cost of Travel Seminar for SD Qualifier is MXN12,500/pax.

Therefore:

Your Travel Seminar Incentive as SD Qualifier

$$= 50\% \times \text{MXN}1,800,000 \times \frac{140,000 \text{ pts}}{5,000,000 \text{ pts}} = \underline{\underline{\text{MXN}25,200}}$$

Note: Your TSI is more than enough to pay for two persons to attend the Travel Seminar. So, you can go for this Travel Seminar with your spouse. There is no cash refund for any excess incentive.

"The statements made on this page are hypothetical and merely meant to describe and explain the mechanisms of the Compensation plan and its various bonus features. Any statements made on this page are not meant as earnings claims, nor do they represent any promises or guarantees of specific earnings or earning potential. Specific earnings will be influenced by many factors."

8. One Time Hand Phone Cash Incentive

EXAMPLE

After you have sponsored 3 immediate SA who achieved 2,400 Accumulated GPV.

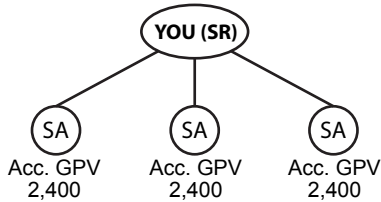

YOU are qualified to receive the One Time Hand Phone Cash Incentive amounting to MXN3,600.

9. One Time Overseas Trip Cash Incentive

EXAMPLE

After you have 5 immediate downlines who have received their Hand Phone Cash Incentive, Then you are qualified for this One Time Oversea Trip Cash Incentive.

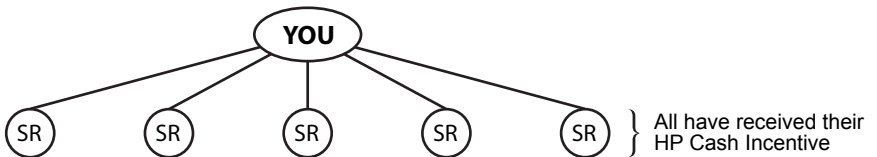

Therefore:

Once YOU have fulfilled the requirements, YOU are qualified for One Time Overseas Trip Cash Incentive amounting to MXN21,600.

"The statements made on this page are hypothetical and merely meant to describe and explain the mechanisms of the Compensation plan and its various bonus features. Any statements made on this page are not meant as earnings claims, nor do they represent any promises or guarantees of specific earnings or earning potential. Specific earnings will be influenced by many factors."

How to become a Star Diamond within 5 months

Assumptions:-

- Personal Sales for each distributor is 40PPV per month.
- Each distributor sponsors 3 new distributors in each month.
- 1 PV = 12 SV

1st Month

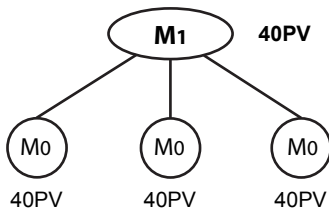

Your status : Distributor - 160PGPV (9%)

Personal PV (PPV)	=	40PV
Personal SV (PSV)	=	480SV
Personal Group PV (PGPV)	=	160PV
Personal Group SV (PGSV)	=	1,920SV
Accumulated PGPV	=	160PV

Your Bonus Income		
Group Bonus	= 1,920SV X 9%	= MXN172.80
Less: Downlines Bonus	= (3 X 480SV X 6%)	= (MXN 86.40)
YOUR Bonus Income		<u><u>MXN 86.40</u></u>

"The description of how to achieve Star Diamond in 5 months is for illustration purposes only, and should not be construed in any manner as either representing that a particular individual will be able to achieve such status or that achieving this position is easy. Individual results will vary."

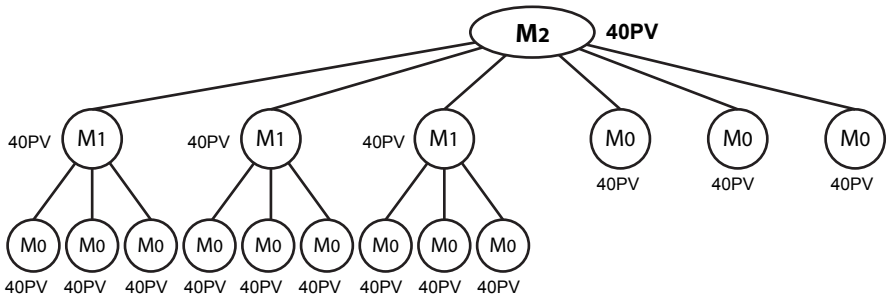

Your status : Distributor - Accumulated 800 PGPV (15%)

Personal PV (PPV) = 40PV
 Personal Group PV (PGPV) = 640PV
 Personal Group SV (PGSV) = 7,680SV

Accumulated PGPV b/f = 160PV
 Accumulated PGPV c/f = 800PV

Your Bonus Income		
Group Bonus	= 7,680SV X 15%	= MXN1,152.00
Less: Downlines Bonus	= (1,920SV X 9% X 3) + (480SV X 6% X 3)	= (MXN 604.80)
 YOUR Bonus Income		 <u>MXN 547.20</u>

"The description of how to achieve Star Diamond in 5 months is for illustration purposes only, and should not be construed in any manner as either representing that a particular individual will be able to achieve such status or that achieving this position is easy. Individual results will vary."

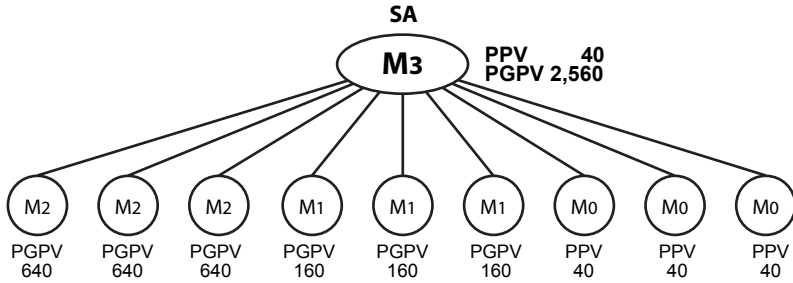

Congratulations! You have reached 1,800 Accumulated PGPV and you are now a Star Agent.

Personal PV (PPV) = 40PV
 Personal Group PV (PGPV) = 2,560PV
 Personal Group SV (PGSV) = 30,720SV

Accumulated PGPV b/f = 800PV
 Accumulated PGPV c/f = 3,360PV

Your Bonus Income

Group Bonus	= 30,720SV X 25%	= MXN7,680.00
Less: Downlines Bonus	= (7,680SV X 15% X 3) +(1,920SV X 9% X 3) +(480SV X 6% X 3)	= (MXN4,060.80)

YOUR Bonus Income MXN3,619.20

"The description of how to achieve Star Diamond in 5 months is for illustration purposes only, and should not be construed in any manner as either representing that a particular individual will be able to achieve such status or that achieving this position is easy. Individual results will vary."

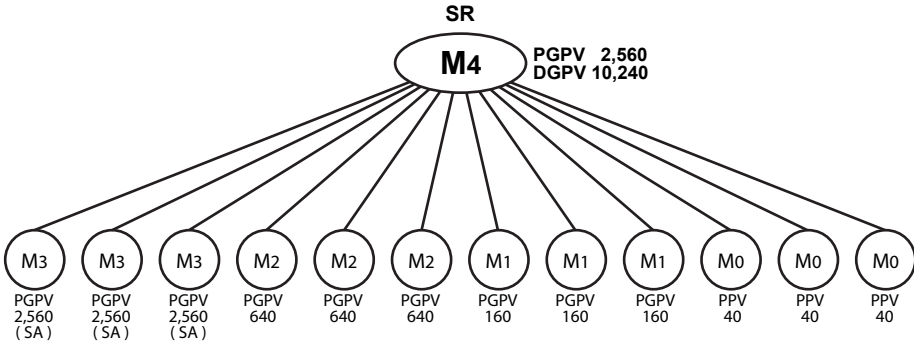

Congratulations! You have successfully promoted 3 direct Star Agent under you, and therefore you are now a Star Ruby.

Personal PV (PPV) = 40PV
 Personal Group PV (PGPV) = 2,560PV
 Personal Group SV (PGSV) = 30,720SV
 Diamond Group PV (DGPV) = 10,240PV
 Diamond Group SV (DGSV) = 122,880SV

Your Bonus Income

Star Group Bonus	=	122,880SV X 31%	=	MXN 38,092.80
Less: Downlines Bonus	=	(30,720SV X 25% X 3)		
		+ (7,680SV X 15% X 3)		
		+ (1,920SV X 9% X 3)		
		+ (480SV X 6% X 3)	=	(MXN 27,100.80)
				MXN10,992.00
Development Bonus	=	30,720SV X 5% X 3	=	MXN 4,608.00
HP Cash Incentive				MXN 3,600.00
Your Bonus Income				<u>MXN19,200.00</u>

"The description of how to achieve Star Diamond in 5 months is for illustration purposes only, and should not be construed in any manner as either representing that a particular individual will be able to achieve such status or that achieving this position is easy. Individual results will vary."

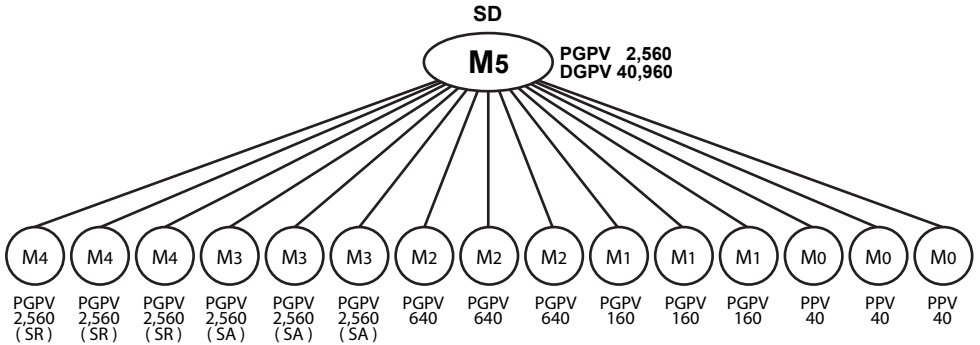

Congratulations! You have successfully promoted 6 SA (1st Generation) and have also met the 5,000DGPV quota. Hence you are now a Star Diamond.

Personal PV (PPV) = 40PV
 Personal Group PV (PGPV) = 2,560PV
 Personal Group SV (PGSV) = 30,720SV
 Diamond Group PV (DGPV) = 40,960PV
 Diamond Group SV (DGSV) = 491,520SV

Your Bonus Income

(A) Star Group Bonus = 491,520SV X 37% = MXN181,862.40
 Less: Downlines Bonus = (122,880SV X 31% X 3)
 + (30,720SV X 25% X 3)
 + (7,680SV X 15% X 3)
 + (1,920SV X 9% X 3)
 + (480SV X 6% X 3) = MXN141,379.20 **MXN 40,483.20**

(B) Development Bonus
 1st Level = 30,720SV X 6 X 5% = MXN 9,216.00
 2nd Level = 30,720SV X 9 X 4% = MXN11,059.20 **MXN 20,275.20**

(C) International Profit Sharing
 Assumption:- = MXN200,000
 i) IPS Fund = 25,000,000pts
 ii) Total IPS Point for all Qualifiers = 491,520SV X 100%
 iii) YOUR IPS Point for the month = 491,520pts

Your International Profit Sharing

= MXN200,000 X $\frac{491,520pts}{25,000,000pts}$ = **MXN 3,932.16**

Your Bonus Income

MXN 64,905.56

"The description of how to achieve Star Diamond in 5 months is for illustration purposes only, and should not be construed in any manner as either representing that a particular individual will be able to achieve such status or that achieving this position is easy. Individual results will vary."